

Granville Arts Center

Brownlee Auditorium

Technical Specs – Quick Sheet

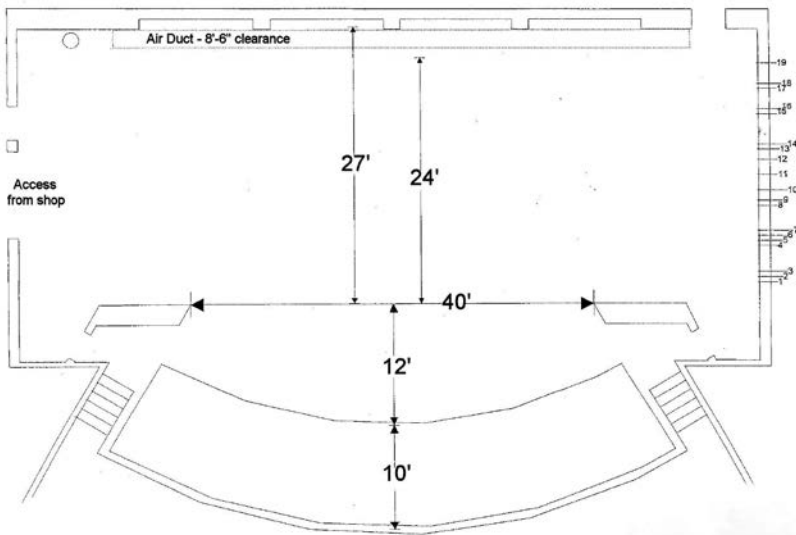

Continental Seating for 720. There is no center aisle.
8 Wheelchair & Removable Seats.

Proscenium: Width: 40'
Height: 20'
Depth (curtain to back wall): 27'
Depth (curtain to back batten): 24'

Apron: Depth (with pit up): 22'
Depth (with pit down): 12'

Wing Space: SL: 16'
SR: 16'

Crossover: Outside corridor in hallway
Back Wall: Air duct with 8' - 6" clearance
Stage Height: Audience floor to stage floor 2' - 5 1/4"
Floor: Stage floor is 1" tongue and groove natural oak with light finish on 3/4" tongue and groove plywood subfloor over 2"x4' sleepers at 16" o.c.

Orchestra Pit:
Curved.
Comfortably holds 20 piece orchestra excluding grand piano.
Door access from audience to pit area.
Width: 60' Depth: 0" to 6'- 6"

Loading Dock:

Ground level access from outside, uncovered, into 40'x40' scene shop with no elevated dock and no height restriction for trucks.
Doors are 7' - 10" wide x 7' - 10" tall from outside into scene shop, then 7' - 6" wide x 18' tall doors from shop to stage.

Dressing / Waiting:

2 - 10'x16' dressing rooms and 2 - 13'x16' dressing rooms equipped with mirrors, lights, electrical plugs and restrooms. 1 16'x21' green room with microwave and small refrigerator.
1 26'x37' rehearsal hall.

Electrical:

Light Booth is in rear of house, center.
Main feed: 1000A; 3-phase
Control: ETC ION Console
192 Control Channel
Dimmer per circuit - 130 -2.4kw circuits
Electronic soft patch
Remote focus unit -
Connectors: L5 - 20p twist lock
Followspots: 2 Lycian model #1209 HP Midget*
Luminaries: 22 ETC Source 4 750 W (19")
16 ETC Source 4 750 W (26")
31 ETC Source 4 750 W (36")
18 Fresnels 8" 1000W
4 sets 3 color cyc strips 1000W
11 ETC 6" parnels
35 PAR 64 1000W

Rental Equipment:

These items are available for an additional rental charge:
*Steinway 9' Grand Piano
*Followspots
*Wireless Microphones
*Hitachi Projector CP-WX9210
WXGA 1280X800
8500 ANSI; 2500:1
(fixed position)

Rigging:

Locking rail is stage left.
Fly loft height: 50' (approximately)
Number of lines: 19
Length of battens: 42' to 52'
Arbor Capacity: 800 lbs, - 1000 lbs.
Loading area: Stage Left Floor
Front Curtain: Traveler Operation
Battens are: 2" Diameter

Audio:

Sound booth is in rear of house, center.
Console: Behringer X32
40 Input, 25 Bus digital mixing console
32 programmable MIDAS Preamps
25 motorized faders, channel LCD's
USB Audio interface
House: Mono center line array cluster
3 - JBL VRX932LA speakers
Bass: 1 - JBL VRX900 Subwoofer
Monitors: 6 portable wedges
2 dead-hung overhead facing stage
Playback: CD
Comm: Clear-Com in booth, backstage and spotlights
Wireless: 6 SHURE ULX Wireless Lapel and 7 SM58 Handheld microphones
2 SHURE LX4 Wireless Lapel

Technical Coordinator:

Theresa Clapper

972-205-2786

tclapper@garlandtx.gov

09/16

Line Set Schedule

Line #	Item	Distance from Proscenium
1	Main Border	1' - 7 1/2"
2	Main Drape	2' - 1 1/2"
3	1 st Electric	2' - 7 1/2"
4	OPEN	5' - 1 1/2"
5	Black Legs	5' - 7 1/2"
6	OPEN	6' - 1 1/2"
7	OPEN	6' - 7 1/2"
	Dead Hung Florescent @25' fixed height	7' - 7 1/2" to 8' - 7 1/2"
8	Border	9' - 1 1/2"
9	Black Traveler	9' - 7 1/2"
10	2 nd Electric	10' - 7 1/2"
11	OPEN	12' - 1 1/2"
12	OPEN	13' - 7 1/2"
13	Legs and Border	14' - 7 1/2"
14	3 rd Electric	15' - 1 1/2"
15	OPEN	18' - 1 1/2"
16	Black Traveler	18' - 7 1/2"
	Dead Hung Florescent @25' fixed height	19' - 6" to 20 - 1/2"
17	OPEN	20' - 7 1/2"
18	OPEN	21' - 1 1/2"
19	Cyclorama, white	23' - 1 1/2"